

FORKLIFT ATTACHMENT

TECHNICAL SPECIFICATIONS

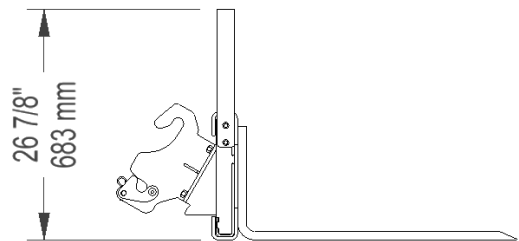
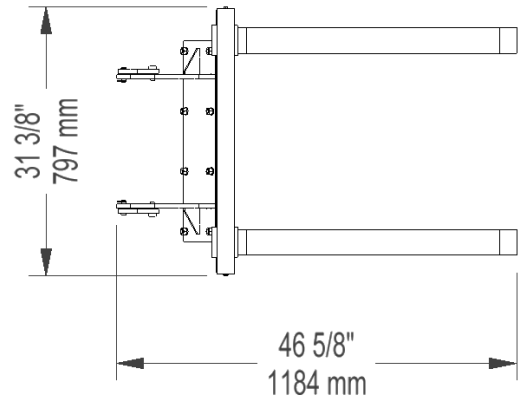
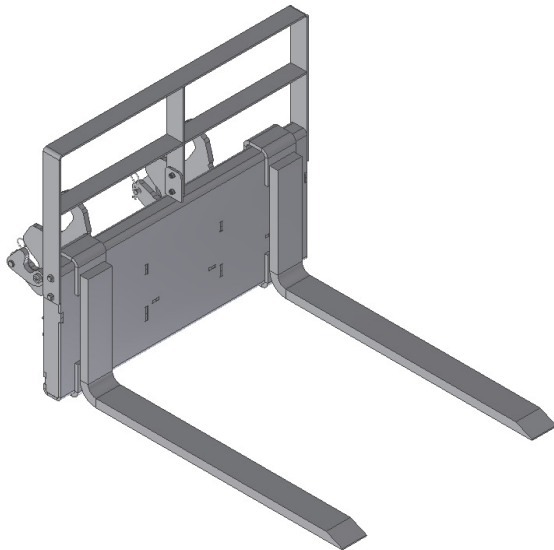
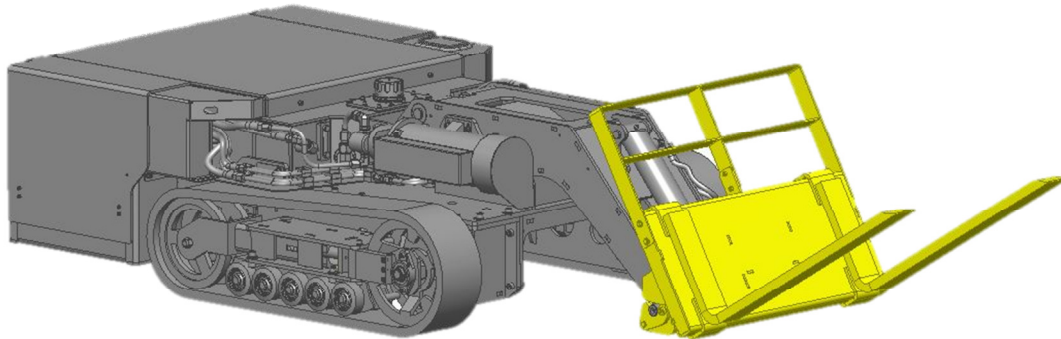

PHYSICAL CHARACTERISTICS

Material	Steel	
Length	46 5/8 "	1184 mm
Width	31 3/8 "	797 mm
Height	26 7/8 "	683 mm
Weight	200 lb	91 kg
Lifting capacity*	335 lb	152 kg

COMPATIBLE WITH :

- MINIDOZER M-27 & M-48
- MINIDOZER AL27 & AL48

* Other capacities available on request

The information contained in the document is subject to change without notice.